

KAPPA 55 DIMENSIONS

All Dimensions are WITHOUT Control Unit or Regulator

Dimensional Drawings are Shown in Millimeters. To Convert to Inches, Multiply Dimension x 0.03937

Specifications

KAPPA 55

Inlet Port - Hose Barb	1-1/4" HB
Outlet Ports - Hose Barb	(2) 1/2" HB
Bypass - Hose Barb	3/4" HB
Dimensions	9.5"L x 12.5"W x 10.5"H
Diaphragm Material	GREENTECH (Std) Buna-N (Opt)

Lubrication: Requires 23 oz. of Udor Lube 40W Premium Pump Oil. Alternate Oil: 30W non-detergent or 15W-40 non-detergent oil.

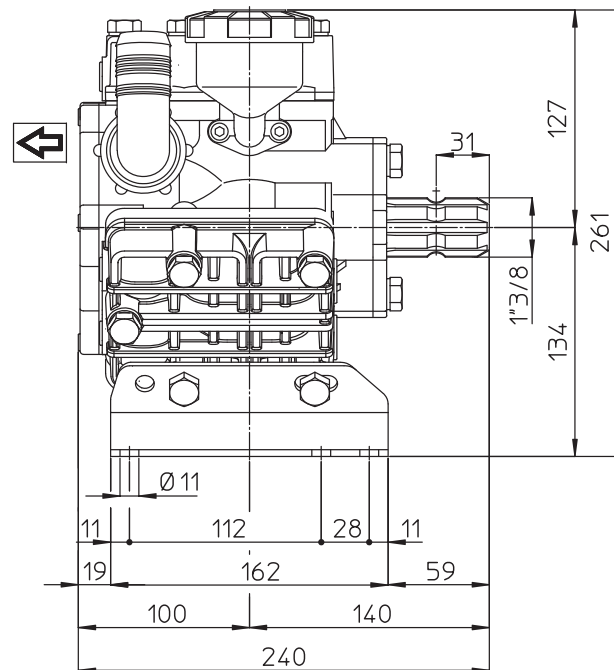
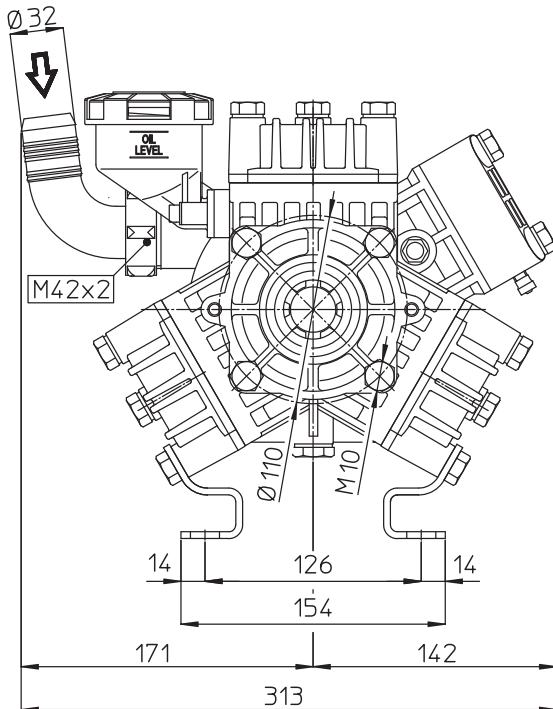

TORQUE SPECS

Ref.	Description	Ft./lb.	Nm
1	Diaphragm Bolts (Use Loctite 243)	18	25
2	Head Bolts	30	40
3	Pulsation Dampener Bolts	30	40
4	Inlet Flange Bolts	7	10
5	Bearing Flange Bolts	25	34
6	Oil Cup Bolts	6	8
7	Valve Cover Bolts	N/A	N/A

